

## EWO

Energy - Water - Optimization

*The Natural Vitalization of Water*



**PROTECTION FROM CALCIUM AND RUST DEPOSITS**

# TABLE OF CONTENTS

**FOREWORD BY THE INVENTOR HIMSELF** 2

**GUEST COMMENTARY BY MR. JÖRG SCHAUBERGER, M.A** 3

**ADVANTAGES OF THE EWO DEVICES** 4

**CROSS-SECTION VIEW OF THE DEVICE FOR PIPES** 5

**TESTIMONIALS (PART A)** 6 – 9

**OVERVIEW OF ALL OUR PRODUCTS** 10 – 11

**TESTIMONIALS (PART B)** 12 – 15

**FUNDAMENTAL PHYSICAL PRINCIPLES OF GRUBER`S WATER VITALIZATION** 16 – 17

**RESULTS OF MASARU EMOTO`S RESEARCH IN JAPAN** 18

**DISSERTATION WORK AT THE UNIVERSITY OF VIENNA AND SERIES OF WORKSHOPS** 19

**SENDER, SALES, GETTING IN TOUCH, SPECIFICATIONS** 20

## Foreword by the Inventor of EWO

*Water – a principle source of nutrition – is becoming more and more important for the health and well-being of all living creatures. For many, however, access to the cleanest possible drinking water is almost impossible. This has led to a world-wide search for ways to obtain pure water that is rich in energy. We at Naturkraft, Inc. spent years researching to what extent environmentally-*



**The Natural Scientist Alois Gruber, inventor of the EWO devices**

*friendly technology can yield such energized water.*

*We are proud to say that our series of EWO products is a valuable contribution to conserving the world-wide supply of drinking water. The EWO products combine both innovative*

*approaches and existing knowledge. The significance of vitalized water will be all the greater the more researchers world-wide take a good look at the concept of the memory of water. Many of them still aren't familiar with the connection between water that has been purified but is nevertheless polluted by negative carriers of information. Hence they continue to find it illogical. Yet science has a responsibility to the general public to shed light on the transfer of information from water cluster structures, even over a distance that doesn't allow any direct contact. On the following pages we'd like to provide you with the basic background information about the "Energizing and Vitalization of Water" by means of EWO technology.*

Sincerely,  
Alois Gruber

# Are humans allowed to vitalize water?

by Jörg Schaubeger, M.A., grandson of the legendary water researcher Viktor Schaubeger



**Water is life – again and again, this was emphasized by ancient religions, myths and fables. Water vitalization, on the other hand, is a topic that did not become current until recently. Why vitalize water? Are humans actually allowed to do that? Isn't it really rather presumptuous if one believes he / she is able to "teach" water anything?**

**A**side from the fact that our number one giver of life is treated with filter systems and chemicals (chlorination, etc.), the main thrust of modern-day water research is on physical variables



**Viktor Schaubeger, the pioneer of water research**

such as pressure, motion or radiation.

A positive example is the waterfall. The water is pulled downward by gravity, falling first as a braid of water. More delicate structures then form, caused by the resistance of air and the earth's magnetic field, which has an effect on the water molecules. They are magnetic dipoles. The falling water itself creates an electric field as well as a roaring sound, which contains virtually all of the audible and inaudible

frequencies. During the day the water is exposed to the rays of the sun, round the clock other sources of cosmic and earthly influence affect it, such as the proverbial fragrant air. At the bottom the water meets the rocks, breaking off minerals. In addition, the rocks' own frequencies (for instance, quartz crystals) have an effect on the structure of the water. In the merry whirling and swirling over the stones the water builds up its energy again. For a human being, an encounter with water like this constitutes in the truest sense of the word the purest kind of pleasure.

Now the different kinds of physical influences on water are increasing. If one sees water as a living organism, then there are physical forces that affect its psyche. We humans rape water, which loves nothing more than its freedom. Our drinking water is often transported many miles under high mechanical pressure in straight, narrow pipes that at times run parallel to high power lines. Then in our homes it is condemned to stand still for hours, is exposed to additional electronic smog and generally ignored.

This is where responsible water vitalization comes in. In the gentlest way possible the water's own essence – and with it its power – should be restored to it. This isn't done by giving the water an overdose of certain substances, which would be nothing other than substance abuse or doping. Water is very sensitive (just like human beings, who consist mainly of water). It reacts to every single external interference, often with surprising results. A lot of adventurers on the water treatment front are not at all aware of what they're doing to the water with their more or less well-intended methods. The most important thing is that they're making money!

Be wary of methods that don't make sense. The simplest and most effective power to purify, regenerate and activate is in the whirling action. In Schaubeger's view it should be given priority if one wants to restore water to its original healthy condition. And whatever one does with water, a certain humility should be present – for the well-being of the water and with that for the benefit of all of humanity.

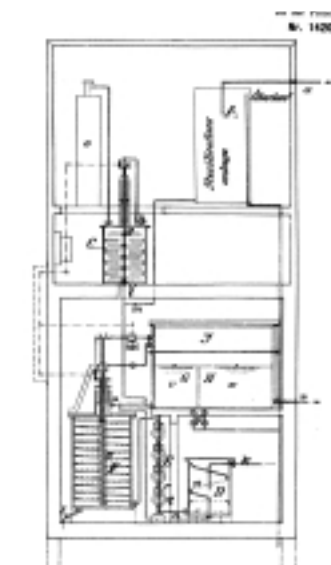

**Viktor Schaubeger: the process for producing water that is similar to spring water**

Jörg Schaubeger

Please note the PKS workshops that take place at our Pythagoras Kepler School, as described on page 19.



# EWO

Energy - Water - Optimization

## the natural solution!

Clear advantages for the user are what make our series of EWO devices stand out:

### ADVANTAGE OF THE EWO WATER VITALIZATION

- Due to the water's decreased surface tension, less detergent, cleaner and disinfectant are needed. The water takes on a higher cleaning capacity.
- EWO water feels softer (for bathing, swimming, showering and sauna baths); significantly less skin irritation
- By energizing the water in the heating system, savings of about 5% - 7% of total heating costs have been achieved due to the fact that the water has a greater ability to take up and give off heat.
- Calcium and rust deposits in pipes and water heaters as well as household appliances are reduced. As a result maintenance costs are much lower.
- Lower costs for cleaning and maintenance
- The water becomes less susceptible to germs, reducing the amount of chlorine necessary in a swimming pool by up to 70% depending on the water quality (costs less and eliminates nasty chlorine odor).
- The water and every thing that is made using it (in the kitchen, for example) taste better. Bread baked in bakeries that use EWO devices stays fresher longer, and butchers report that cold cuts and sausages have a longer shelf-life.
- Plants are noticeably healthier and grow better. Their metabolism improves, resulting in more robust plants and less loss.

### THE ADVANTAGES OVER OUR COMPETITION

#### • **No maintenance or operating costs**

The operation of the EWO water vitalizer is cost free. Neither electricity nor refilling salt, etc. is necessary.

#### • **EWO makes use of the natural frequency of the Earth's magnetic field**

of approximately 8 hertz. This magnetic field ensures the re-shaping of the calcium crystals. No other frequencies exist in nature!

#### • **EWO whirls the water**

according to our model invented by the natural scientist Viktor Schaubeger. A number of scientific studies revealed that it is the vigorous whirling of the water that is highly significant. During this process the water clusters are re-shaped and, as a result, biologically prepared for being re-programmed.

#### • **EWO "energizes" the water flowing through it**

using a highly energetic, liquid filling. This information, taken from the purest spring water and enriched with the original information of all sorts of rock strata from the geological genesis, is transferred to the water flowing past it without coming into direct contact with it.

**It is the useful combination of these three natural methods that lends the EWO technology its uniqueness, a subject which will be dealt with further in a soon-to-be-published dissertation.**



## The Secret – or the most natural thing in the world

TAP WATER



### THIS IS HOW IT WORKS:

In the EWO device water is guided through a technically sophisticated DNA-like spiral which vigorously whirls it around, preparing it for the optimum absorption of energy and information.

When water flows through the magnetic field, its calcium crystals are transformed (calcite becomes aragonite).

Because of the whirling and the magnetism, the water is now ready to take on or adopt new "information", which it receives at once from the "Gruber Information Water".

### THE DNA-LIKE SPIRAL

It is already almost 70 years ago that Viktor Schaubeger discovered that vigorously whirled water has a special capacity to absorb positive energy.

In nature, the natural flow of water causes this whirling effect.

EWO WATER

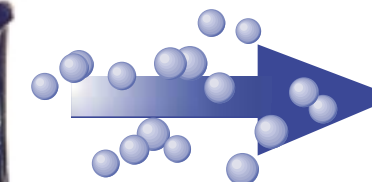

### TRANSFORMATION OF THE CALCIUM CRYSTALS

Using the same frequency as the Earth's magnetic field, the magnetized exterior acts on the interior to build up a magnetic field which transforms the crystalline structure of the calcium. The resulting form of calcium can no longer leave deposits in pipes or water heaters and is flushed out.

### THE FILLING OF "GRUBER INFORMATION WATER"

This highly energetic filling consists of the highest quality spring water and special minerals.

Since a water molecule is a dipole (magnets that can be lined up), this natural information can now be transferred to the prepared tap water.

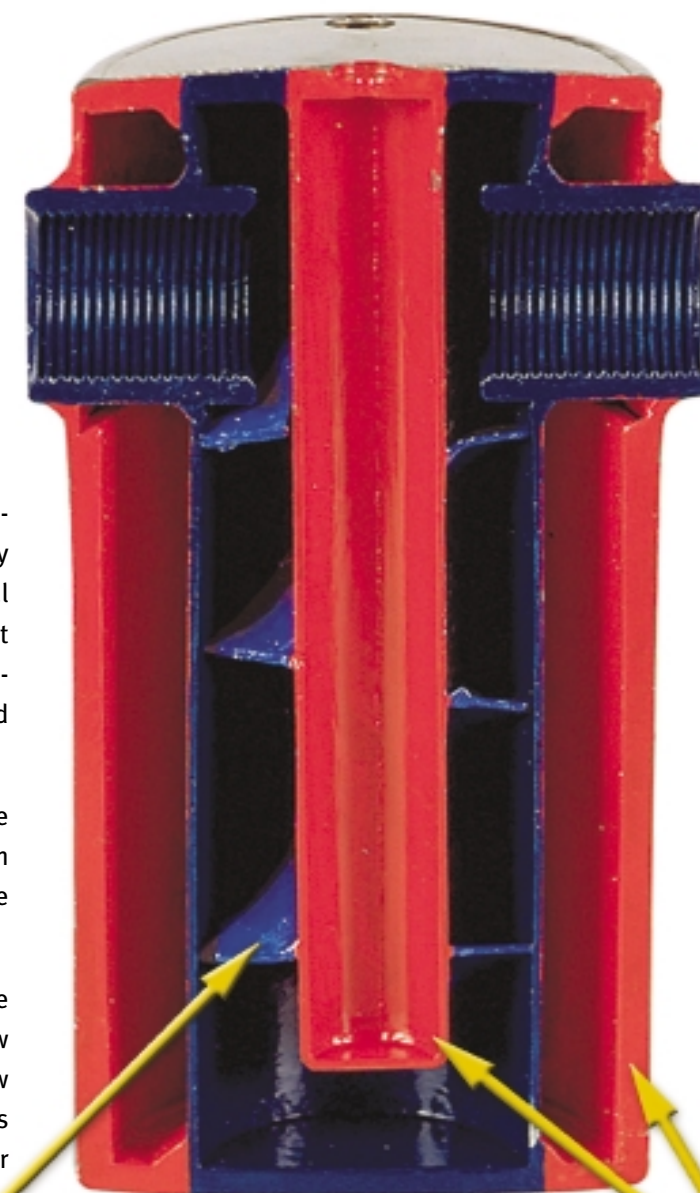

USERS' REPORTS FROM THE PRIVATE SECTOR

**Bernhard Gusenbauer, Farmer, Naarn, Upper Austria**



*Offensive odors have been drastically reduced  
Plants can absorb fertilizer immediately  
Use of chemicals in household reduced*



• EWO – a spring in your house • EWO – vitalized water • EWO – a spring in your house • EWO – vitalized water

We use two EWO devices on our farm – one in the well (for drinking water) and one in the liquid manure pit. With the drinking water (24° water hardness) we immediately noticed that the water is much softer and gentler on our skin. My wife no longer uses any fabric softener in the wash or salt in the dishwasher. On the pig farming side of things, there aren't any problems any more like clogged nipples on the drinking units (due to mineral deposits). Since the animals drink more of the vitalized water, our watering system also works better. With the liquid manure pit we've noticed over a longer period of time that a hard cover no longer forms on the top. The bad odors have gotten much better, and the plants can absorb fertilizers right away. I can highly recommend these devices to any farmer who doesn't use antibiotics.

**Family P., Steinabrückl**

Extract from a letter to Naturkraft, Inc.:

*Scars clearly heal better*

*In spite of our initial skepticism, we decided to install an EWO device. Then my wife had an accident and burned her legs. Since she has been taking a bath in the vitalized water every day, the scars have clearly healed better and the scar tissue is soft to the touch.*

• EWO – a spring in your house • EWO – vitalized water • EWO – a spring in your house • EWO – vitalized water

**Rosa Farm – Vitalization of the Liquid Manure Pit**



*Offensive odor greatly reduced  
No cover forms on top  
Remarkably better growth*



• EWO – a spring in your house • EWO – vitalized water • EWO – a spring in your house • EWO – vitalized water

We'd been having a lot of problems with our liquid manure (very ropy, a hard cover formed on top, nasty odor), so in the fall of 1999 we installed an EWO vitalizer in our well. Already in November 1999 the manure was spread on the fields. What was most remarkable was the fact that it didn't smell so bad, a fact that also really impressed our mayor, who was there at the time. The big difference in smell was clear when we spread vitalized and unvitalized liquid manure. During the winter no hard cover formed on top and the manure didn't change its liquid form. In spring it was much easier to stir the manure and fill it into the container for spreading. There was naturally less odor on the fields, and whatever smell was present already disappeared after one day instead of lingering for two or three days. The plants have been growing remarkably better, the young corn plants have been developing faster, too. We're extremely satisfied!



USERS' REPORTS FROM THE SERVICE SECTOR

**Kursana Home for Senior Citizens, Linz, Upper Austria**

*The best quality drinking water  
Savings of 25,000 Euros a year  
No maintenance costs*

• EWO – a spring in your house • EWO – vitalized water • EWO – a spring in your house • EWO – vitalized water

Mrs. Koller, Director:

*"Since we got vitalized water, everyone's been so thrilled with the quality of the water that all we drink is tap water."*

Results:

- Best results in all areas of application
- No mineral deposits
- No maintenance costs
- Less detergent and cleaner necessary
- Excellent quality of drinking water

Stefan Kraftfeld, Technician:

*"The water softener that we used to have cost us ATS 350,000 a year to operate. Now we're saving that money."*

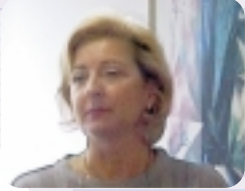

Mrs. Koller, Director



Stefan Kraftfeld, Technician

**Winkler Supermarket, Linz, Upper Austria**



*Vegetables stay fresh noticeably longer*

• EWO – a spring in your house • EWO – vitalized water

2 EWO 1" Units

- Calcium rings on the stainless steel tubs are much easier to wipe off
- Vegetables stay fresh noticeably longer after having been washed with energized water
- Drinking water tastes more refreshing

**Rottenmann Provincial Hospital**



*Rust problems solved by an EWO device*

• EWO – a spring in your house • EWO – vitalized water

Rottenmann Provincial Hospital

*Big problems with rust and with corrosive and brown water: After installation, all of these problems were solved.*

Results:

*Water is clear again and the calcium spots are easier to remove (lower cleaning costs).*



USERS` REPORTS FROM THE TOURIST INDUSTRY

USERS` REPORTS FROM THE TOURIST INDUSTRY

**Health Spa Bad Schönau, Lower Austria**



*Less disinfectant  
The best quality drinking water  
No more problems with calcium deposits*

**Mr. Gerhard Schemann, Director**



**3/4" EWO device installed in the underfloor heating system**

- approximately 6% savings on energy
- no build-up of sludge
- pleasant atmosphere in the rooms
- Our employees no longer have swollen feet or legs and generally feel better.

**Mr. Franz Ungerboeck, Technician**



*The Health Spa Center "Landsknechte, Inc." uses EWO technology in the following locations:*

- Bad Schönau
- Hotel Kaiserblick
- Bad Häring
- Bad Eisenkappel

**4" device in the drinking water supply**

- 1/3 less chlorine used in all pools
- less offensive chlorine odor
- less irritation of eyes and skin
- Guests are thrilled with the water quality.
- improved conductivity of the water shown by regular test results (every 6 months)
- We've currently reduced the amount of chemical detergents and cleaners by 1/3.
- Calcium spots on dishes or plumbing fixtures are easy to remove, and kitchen appliances no longer build up calcium.

**Hotel Peternhof, Kössen, Tirol, Austria**



*Calcium deposits no longer a problem*

**Mr. Christian Mühlberger, Hotel-keeper:**

*"Our hotel offers a high degree of comfort in its well-developed health spa facilities, so naturally we place very high demands on the quality of our water.*

*By installing the EWO device in the pipes we were able to solve problems like calcium deposits in various warm water appliances. Objective observers have confirmed our impression that the water feels softer and gentler on our skin."*

**Hotel Brückenwirt, St. Johann, Tirol**



*No problems with calcium build-up in the kitchen or health spa facilities*

**Results following installation of a 6/4" EWO device in the central water supply:**

- no more calcium deposits in the showerheads
- calcium rings and spots in bathrooms and spa areas easy to remove
- guests thrilled about the quality of the drinking water
- fewer chemical cleaning agents and disinfectants necessary

**Hotel Schatzberghaus, Wildschönau, Tirol**



*Problems: rust in the water and restricted flow of water*

**Mr. Spöck:**

*"The water supply at the Schatzberghaus had caused us major problems with rust and restricted water flow for 30 years.*

*After we'd talked about seven different possibilities to deal with these problems, we came across the EWO device, and in my opinion I have to say that it works."*

**The Provincial School for Physical Education and Sport, St. Pölten, Lower Austria**



*No more mineral deposits, and the quality of the drinking water is the best.*

*The Provincial School for Physical Education and Sport is the venue for important sports events (such as the Association of Tennis Professionals competition) as well as the sports center for our students and other athletes. It houses an 80-room hotel.*

- We drink a lot more tap water, because now it tastes so good.
- Washing your hands is much more pleasant.
- The plants grow better.
- Calcium spots are wiped away with just a damp cloth.
- It's no longer necessary to use caustic cleaning agents.
- The glassware washer and the coffee maker in the restaurant no longer build up calcium.
- Our employees and guests only have positive things to say.

**Hotel Kaiserblick, Tirol, Austria**



*The swimming pool is now heavenly*

**Installation of a 2" EWO device for the pipes in the central water supply**

- top drinking water quality
- no more calcium deposits
- less chlorine necessary to disinfect the swimming pool
- less unpleasant chlorine odor

**Bad Tatzmannsdorf, Styria, Austria**



*Better water quality*

**A 2" EWO device for the drinking water supply and swimming pool has improved the water quality and reduced chlorination.**

**A 3/4" EWO device for pipes was installed in the heating system.**

- has prevented build-up of sludge
- has achieved savings on heating costs
- no more swollen feet or legs



Energy - Water - Optimization

# brings the spring into your home...

## PIPE INSTALLATION



The EWO device can easily be installed in the water supply line of your house or apartment behind the water meter and the main faucet. The cross-section of the pipe will determine which type of device best suits your needs. We strongly recommend you have the device installed by a skilled plumber. Areas of application: homes, apartments, restaurants, farms, nurseries, swimming pools, closed circuit water systems, heat exchangers, cooling systems, car washes, laundromats, industrial plants, etc.

## INSTALLATION IN YOUR HOME



To install your EWO device, simply unscrew the top of the cold water stopcock and replace it with the EWO device. You shut off the water flow the same way as always. If you move, you can easily remove the EWO device and take it with you to your new home.

## VITALIZATION OF WELL WATER



EWO devices for wells, swimming pools, water treatment facilities and liquid manure pits can be installed simply by attaching them to a 5-mm-long nylon rope.

- for wells: place 20 - 30 cm above the bottom
- for swimming pools: place 10 cm above the bottom of the equalizing reservoir
- for water treatment facilities and liquid manure pits: place in the upper third of the container; for use only with aerobic bacteria phyla.

- Protection from Calcium and Rust
- Purification of the Body
- Protection from harmful Frequencies
- Better Taste
- Softer Water
- Plants Grow Better



# ... and well-being into your life

## EWO ENERGY BELT



Inside the belt there are tubes filled with energized water, which transfers natural energy to the problem areas of your body. The effect is both vitalizing and balancing.

## ENERGY LOCKET

Our Energy Locket is filled with the high quality "Gruber Information Water", which supplies your body with positive vibrational information. The human body, which of course consists of approximately 70% water, takes in these natural vibrations. It's a stress-buster and also reduces the effects of harmful environmental radiation. You feel more balanced, resilient and energized! Now also available in silver - entirely nickel-free!



## ENERGY WAND

The EWO Wand activates and improves drinking water and all other beverages. You can also use it to wash fruits and vegetables. Stir your drink with the wand for ten seconds and you'll feel the difference and its vitalizing effect. You can also experience its positive biological effects when you carry the wand on your body - a higher level of energy, greater well-being and more harmony will be yours.





## VITALIZING DEVICE FOR HEATING SYSTEMS

This vitalizer is especially designed for installation in underfloor (also called "radiant") heating and wall heating systems. It prevents the build-up of sludge in the water. If it's installed after the heating system has already been in operation, then it will purify the water in the system. The negative side-effects of underfloor (radiant) heating (such as swollen legs, tiredness, aching feet) will disappear, and you'll save 5% - 7% on heating costs.



USERS' REPORTS FROM THE SERVICE SECTOR

USERS' REPORTS FROM GOVERNMENT AGENCIES

**Gas Station König, Schwertberg, Austria**  
Fewer chemicals

Mr. Eugen König, Gas Station Owner

*"We installed the EWO device at our gas station for the car wash. Since then we've used fewer chemicals and it's been easier to clean the car wash. In the meantime we've also been using this technology in our homes because we're convinced that the pipes will have an increased life span."*







**Kia and Mazda Car Dealership Stallinger**  
The EWO device paid for itself after only six months!

- car wash facility: cars get really clean despite a 20% reduction in cleaner
- no more problems with calcium deposits



**Opel Car Dealership Kirchberger**  
Significantly lower amount of cleaner used in the car wash facility

The 1" EWO device paid for itself after only six months!





**Skloib Cabinet Makers, Grein**  
The investment was worthwhile!

**"Life – Living -- Wellness"**

Since installing an EWO device we've had significantly fewer technical problems running the shop.

Mr. Kloibhofer, manager: "The investment was worth it!"







**Raiffeisen Bank, Upper Austria**  
Use of chemicals drastically reduced

By installing a 2" EWO device in both enterprises it was possible to stop the use of chemicals for rust control.

Since that time our employees have once again been in the position to consume good drinking water out of the faucet. We've done away with expensive water fountains. And we've significantly reduced the use of common cleaning agents.

**Upper Austrian Insurance Company, Linz**  
Use of cleaning agents drastically reduced







**Provincial Government of Lower Austria, St. Pölten, Austria**  
Algae growth reduced by approximately 80%

1 4" EWO and 1 1" EWO device

*"In the government complex of the new Lower Austrian provincial capital, St. Pölten, a beautiful fountain was installed in a large basin. In the past we had pretty big problems with the basin, because on the one hand it's very large and on the other hand it's very shallow. With the sun shining on it, the algae began to take over. This year we installed an EWO water vitalization device, which has resulted in longer intervals between cleaning the basin as well as a significant reduction of operating costs."*



Department of Building Engineering  
Mr. Friedrich Käfer, Engineer

**Municipal Office of Parks and Gardens, St. Pölten, Austria**  
EWO Technology solved pond problem

Mr. Johann Pelzer, Engineer

*"I'm the head of the Municipal Office of Parks and Gardens in St. Pölten, so it's my job to plan and take care of the city's greenery and parks. We had major problems with sludge building up in the pond in the one park. It smelled bad and it became a huge job to keep the water clean. The pond's been clean and fine though since we installed an EWO device. It's proved to be really worthwhile."*

**Building Code Supervisor, Sinabelkirchen, Styria, Austria**  
Pipes show no signs of calcium or other deposits

Mr. Gerhard Maninger, Engineer

*"As the building code supervisor, I'm also responsible for the water supply system -- among other things. Our supply lines, including a high rise tank, are currently under construction. The tank will provide water for about 500 households. While the water tank was being renovated, we installed an EWO vitalizing device. Since then the side pipes to the end pieces have been free of calcium and other deposits."*



USERS`S REPORTS FROM THE FOOD INDUSTRY

USERS`S REPORTS FROM (MANUFACTURING)

**Roncadin, manufacturer of baked goods, pizza dough and ice cream, Meduna, Italy**



*Yeast dough rises much better now than it did with normal water.*



Mr. Renzo Roncadin

*"After receiving detailed information from the company Naturkraft, we decided to test how well the EWO technology functions in our bread production. Laboratory tests had shown that dough rose much better than with normal water. This is what we wanted to take advantage of, so an EWO device was installed in the company's main water supply line. In addition an EOW device was installed in my swimming pool at home. Since then I haven't had any more problems with algae and I've been able to significantly reduce the amount of chemicals like chlorine."*



Roncadin is one of the biggest manufacturers of pizza and ice cream in Europe.

**TEWA Packaging, Inc., Manufacturer of Corrugated Cardboard, Feldkirchen, Karinthia, Austria**



*Productivity has increased significantly due to better glue quality.*



Mr. Viktor Billiani, Marketing

Mr. Viktor Billiani, Marketing

"First of all we installed two EWO devices in our homes and got positive results after a short time:

- softer water resulting in much healthier skin (neurodermitis)
- 50% reduction of chemical cleaning agents

We process 120,000 tons of paper a year to make corrugated cardboard, and to do this we need glue, which contains water. Thanks to the consistently high quality water for the glue, we've been able to significantly reduce the number of rejects and increase the quality of the corrugated cardboard!"

Based on these positive experiences, we've just recently installed an EWO device in our factory, too.

**Prindl Bakery, Vienna**



*We've seen a slight improvement in the quality of our baked goods.*

*We have a mid-sized bakery in Vienna and supply restaurants, hotels and grocery stores. Since we installed EWO devices in our bakery, all of the water and steam pipes have been free of calcium. We've been really satisfied since we installed the devices. The quality of the baked goods is still first-class and it's shown a slight change for the better.*

**Puntigam Brewery**



*Good beer made from pure water*

*A 4" EWO device was installed in the water supply line of the brewery in February 2002.*



**Lenzing Plastics**



*The machines were totally clogged with calcium deposits. Now everything's in tiptop condition.*

Mr. Gerhard Nöhmer, Technical Supervisor / Mr. Walter Reichert, Production Manager, Regranulating

*"We used to have a recurrent problem with calcium deposits in the regranulating machine in our plastics recycling plant, even with new machines. After six months the machines were totally clogged with calcium. No water could run through the cooling unit. It was decided to install an EWO device, and since then we haven't had any problems."*

**Zitta Synthetics Manufacturing**



*Lower maintenance costs for machinery*

*Open cooling system for the machinery used in the production of synthetic materials: EWO device prevents calcium from clogging the cooling channels as well as the supply pipes and the circulating pump. Closed systems: The build-up of algae and germs has been reduced. In both systems the installation of an EWO device has solved the following problems:*

- maintenance intervals now longer
- fewer rejects
- machines are cleaned faster and more easily
- lower maintenance costs for machinery

# The Fundamental Principles of Gruber's Water Vitalization

When developing his range of EWO products, Gruber simply modelled them on nature. The combination of all sorts of technologies resulted in the excellent performance of all Naturkraft products.

## VIKTOR SCHAUBERGER'S PRINCIPLE OF WHIRLING

It has been scientifically proven that water clusters (macromolecules) are negatively influenced and altered by pumps, motors, electromagnetic fields, high pressure in pipes and chemical pollutants.

Through Whirling

- the structure of the cluster is altered
- any harmful information left on the altered molecules is cleared
- the surface tension of the water decreases

Just as water naturally whirls and swirls over stones in nature, the EWO device guides the flow of water through a technically sophisticated DNA-like spiral, resulting in the optimum boost of its energy intake. It was Viktor

Schauberger who already almost 70 years ago discovered that water is only capable of absorbing positive energy through vigorous whirling.

The ideal whirling of the water is carried out by the spirals.

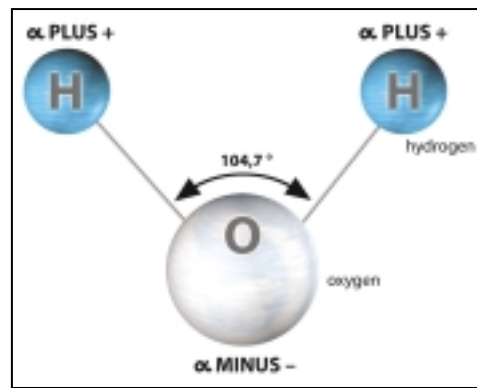

The chemical structure of a water molecule.

## CLEARING HARMFUL FREQUENCIES IN WATER

Harmful frequencies (caused by pumps with electrical frequencies of 50 hertz) or pollution (due to chemicals, medicines, etc) leave their mark on water.

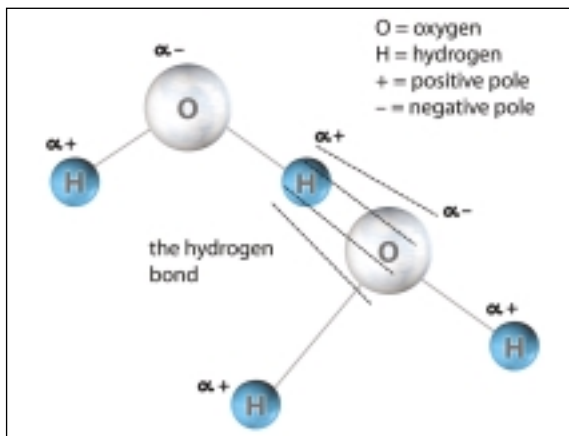

A water molecule is the smallest magnet.

This can be explained in the following way: The soluble pollutants in the water bring in ions that are charged differently. "Water shells" consisting

of dipolar water molecules arrange around the ions, which on account of the polarity attach to the ion (hydrogen bond). Around each ion dissolved in water there are dipole water molecules arranged specifically for this particular ion, which in the end forms a grid structure due to the hydrogen bonding. The human organism (70% water) automatically recognizes the water structure and therefore knows what is dissolved in the water. Consequently water becomes a carrier and/or reservoir of information.

Chemical pollutants leave behind water clusters that are similar to themselves – even after the water has been filtered. These water clusters take on the harmful vibrational activity of the pollutants (and consequently their harmful resonance). They themselves actually carry the harmful information of the chemical pollutants.

By vigorously whirling and accelerating the water in the EWO device, the size and the make-up of all of the water clusters are altered. Consequently, also the structure of the harmful water clusters is destroyed and formed anew by the subsequent transfer of information.



## TRANSFER OF INFORMATION

This example using the Law of Resonance should help to explain the process.

Every body or thing has its own vibration or frequency. It makes no difference if it's a glass, a bell, the human body or water. If a bell is hanging in a room and someone faintly sings the exact tone of the bell, it will begin to ring, because just exactly its own frequency is activated.

This law is valid for all forms of life (people, animals, plants,...). All of these processes again require the existence of a form of energy that underlies life's course of events.

The fundamental vibration of life is identical with the vibration of the Earth's magnetic field, which is dipolar by nature (positive pole, negative pole). Since pure spring water comes out of the ground, it is also endowed with precisely this unadulterated fundamental vibration.

That is why the EWO device can be compared with a copier that can make any number of copies of an

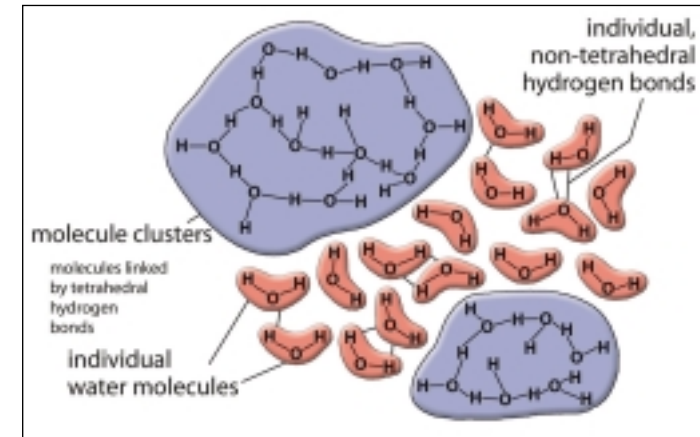

By forming so-called "molecule clusters", water develops a "memory".

original without wearing out the original.

In accordance with this process, the carrier substance in the EWO device is

"Information and Energy Water", a so-called "catalytic converter of information."

## TRANSFORMATION OF THE CALCIUM CHLORIDE THROUGH

### THE EARTH'S MAGNETIC FIELD

By magnetizing the outer steel casing using the natural frequency of the Earth's magnetic field (approx. 8 hertz), the calcium chloride crystals are altered.

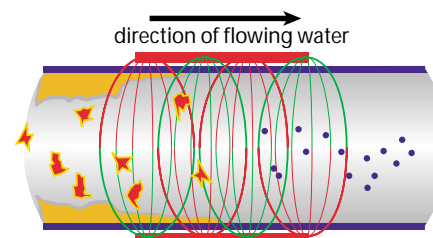

Effect of the magnetic field on calcium crystals: The entire calcite structure disappears due to the re-crystallization of aragonite.

It's a fact that one and the same substance can be found in all sorts of crystalline phases, regardless of whether it's a chemical element or a compound. This is called "polymorphism" (multiple shapes and forms).

due to the influence of the magnetic field. The entire calcite structure disappears through a new process of crystallization in which small aragonite crystals develop. Aragonite crystals cannot build up in water pipes and water heaters and even break down existing calcium and rust deposits.

Results:

- no calcium build-up in pipes and water heaters
- lower cleaning and maintenance costs
- increased life span (coffee makers, washing machines, car washes, heat exchangers, etc.)

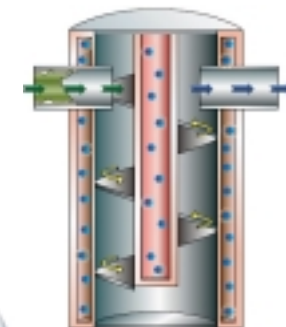

The new aragonite crystals that form in the water while it's flowing through the EWO device cannot build up in the pipes and water heaters.

Calcite: trigonal  
CaCO3 Calcite / Aragonite  
Aragonite: orthorhombic

During the change-over of calcite into aragonite, reconstructive phases of transformation occur



# Water as a Reservoir of Information

*The fact that water is able to store information goes without saying for alternative (or energetic) medicine but is still seriously doubted and regarded as charlatanism by the orthodox natural sciences. However, a Japanese man has furnished the evidence.*

Owing to the book "The Message from the Water" by the Japanese man Masaru Emoto, this argument among scientists has now been decided in favor of alternative medicine.

In 12 years of research he succeeded in scientifically proving beyond a doubt that water is able to store not

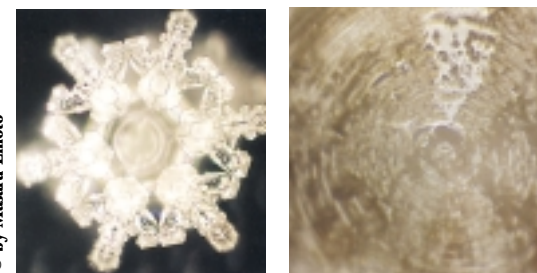

© by Masaru Emoto

**By using a new method Emoto developed himself to photograph water, he was able to prove that water has a memory.**

only information but also feelings and consciousness. In the future, anyone who entertains natural scientists' doubts need only be given Emoto's book. They'll be amazed. Because the "information crystals" pictured there can be reproduced the same way at anytime and by anyone, even if the shapes vary unavoidably. The magazine "Raum&Zeit" has presented Emoto's research work.

## Gunther Wolfgang Schneider, Practitioner of Alternative Medicine, Nürnberg, Germany



**In his book W.G. Schneider explains that vitalized water is of the utmost significance for the detoxification of the body.**

Since 1983 I've been a practitioner of alternative medicine. On the basis of my practical experience I wrote the book "The Human Biotope". Vitalized water is of the utmost importance for our

For twelve years Masaru Emoto researched how the memory of water and its stored information could be made visible. For three years he photographed and analyzed tens of thousands of water crystals. It turned out that the optimum conditions exist when a microscope is cooled to  $-5^{\circ}\text{C}$  to show the crystalized shapes of the water in the best possible way.

A crystal in good water is constructed hexagonally, similar to a snowflake. All around the hexagon there are rows of crystalline ornaments. This construction as well as the color of the crystal and its center provide information about the water's stored information, which can then be interpreted.

The pictures can be interpreted in all different ways, which is why it can now be maintained that – based on scientific research – water is a carrier of information. In his book "The message from the water", Masaru Emoto presents 100 of the most beautiful crystal photographs, which were taken under a microscope. The book marks the beginning of future research.

More information: [www.hado.net](http://www.hado.net)



**Book: "The Human Biotope"**



**Book: "Gruber Water"**

body's cells, because we naturally also need a kind of energy – something comparable to current – for all sorts of metabolic processes. The water that we need today for the de-toxification and purification of our body should contain the most natural vibrations and energies. That's why I'm a fan of EWO water, because in my opinion it contains this individual energy.



**Masaru Emoto: The Japanese man's pictures revolutionized water research**

# Dissertation Work at the University of Vienna on the Subject of EWO

At the University of Vienna a dissertation is currently being written on the subject of water vitalization. The EWO device being tested in connection with that re-

search has shown very positive results. An excerpt from the dissertation will be published in the next issue (to be published in the 4th quarter of 2002).

## Schauberger's Pythagoras – Kepler – School (PKS) Workshops

PKS Workshops are based on the findings of Viktor Schauberg: The Upper Austrian forest ranger Viktor Schauberg (1885 – 1958) is regarded as the pioneer of modern-day water research. He was probably also the first to register a water vitalization device for a patent, which he actually already did in 1935! The success of his "Process for Producing Water that is Similar to Spring Water" soon backfired, because the authorities refused to allow him to manufacture the device. But in its place he received a title: Viktor

Schauberger – the Water Wizard. In Bad Ischl at the headquarters for the administration of Schauberg's estate, Viktor's son, the trained engineer Walter Schauberg, founded the Pythagoras Kepler School (PKS) about three decades ago. For several years PKS workshops have been held there, organized by Ingrid Schauberg, M.A. and Jörg Schauberg, M.A., Walter's son (and hence grandson of the Water Wizard himself).

The following is an excerpt from the PKS schedule of workshops for 2002:

**"Implosion and the Power of the Whirl" For beginners, based on Viktor and Walter Schauberg, August 23 – 25, 2002**

Led by Professor Dr. Norbert Harthun (retired, University of Leipzig) and Uwe Fischer, Engineer, from Bremen. They will focus on Viktor and Walter Schauberg as well as the historical and current developments surrounding Schauberg's nature-based technology.

### The ISBN numbers of books that deal with Schauberg:

NEW! Viktor Schauberg, Our Senseless Work, ISBN 3-902262-00-1  
Viktor Schauberg, Water – Blood of the Earth (CD-Rom), ISBN 3-9500686-2-7  
Olof Alexandersson, Living Water, ISBN 3-85068-377-X  
Callum Coats, Understanding and Using Natural Energies – Schauberg's Ingenious Inventions, ISBN 3-930243-14-8  
Claus Radlberger, The Hyperbolic Cone According to Walter Schauberg, ISBN 3-9500686-1-9

**"The Significance of Water for Health" September 28 – 29, 2002**

The medical doctors Madeleine Calame and Anton Salat will speak on their experiences relating to water as a source of nutrition. Guest Speaker Konrad Richli, who imported Schauberg's environmentally-conscious technology to Switzerland approximately 40 years ago, will also participate.

**"Water – the Original Source of Life" October 19 – 20, 2002**

Dr. Joan Davis will speak on the topic of "Water – Recipient and Mediator of Life-Forming Influences" and Andreas Schulz will talk about "The Power of Life in Water – Made Visible by means of the Analysis of Crystals".

### To register, contact:

PKS / Mr. Schauberg, M.A.  
Kaltenbach 162  
A-4821 Lauffen / Bad Ischl  
Telephone # (06132) 248 14  
Fax # (06132) 248 144  
Price of Workshop: 185 Euros per person

For further information on PKS visit our website at [www.pks.or.at](http://www.pks.or.at)



# See for yourself how well EWO products perform – without risk!

***12 months of guaranteed success (with right of return)***

***10-year guarantee on parts and performance***

**TECHNICAL SPECIFICATIONS: EWO DEVICES FOR WATER PIPES**

Dimension	3/4"	1"	5/4"	6/4"	2"	3"	4"
Item #	E750	E100	E540	E640	E200	E300	E400
Water pressure up to (bar)	10 142	10 142	10 142	10 142	10 142	10 142	10 142
Operating temperature (+°C) (+°F)	1-95 33-200	1-95 33-200	1-95 33-200	1-95 33-200	1-95 33-200	1-95 33-200	1-95 33-200
Max. flow (liters per second) (gal./min)	2 32	3 48	5 80	6 95	9 142	14 221	20 316
Loss of pressure (mega-bar) ( at max. flow)	450	450	450	450	450	450	450
Weight (kg) (lb)	3,7 8,14	4,8 10,5	11,5 25,5	13,5 29,7	21 46,2	42 92,4	55 123,2
<b>Measurements</b>							
Height (mm) (in)	180 4,57	210 5,34	300 7,62	340 8,64	445 11,3	500 12,7	570 14,6
Diameter (mm) (in)	85 2,16	100 2,54	130 3,3	155 3,94	170 4,32	180 4,57	250 6,35

**Distribution partner:**

**Naturkraft U.S.A., Inc.  
70 Church Drive  
Palmerton PA 18071  
USA**

**Telephone: 001/610 681 6974  
www.naturkraftusa.net  
E-mail: office@naturkraftusa.net**

**Made by:**

**Naturkraft, Bio-Technologie GmbH  
Lacken 20  
A-4112 Rottenegg,  
Telephone # 0043/7232 275 4-0  
Fax # 0043/7232 275 4-4  
www.naturkraft.at  
E-mail: office@naturkraft.at**

